

Model	From serial #
HS-6013	2.110.001
EH030	1.460.001
HS-6017	2.120.001
EH040	1.470.001

Serial #

Shipping date

Installation instructions for washers HS-6013 / HS-6017 EH030 / EH040

GIRBAU, S.A.

Crta de Manlleu, km. 1
08500 VIC (Barcelona) • SPAIN
Tel. 34 93 8861100
Fax 34 93 8860785
girbau@girbau.es
www.girbau.com

For USA & CANADA:

CONTINENTAL GIRBAU Inc.

2500 State Road 44
WI 54904 Oshkosh • USA
Tel. 1(920) 231-8222
Fax 1(920) 231-4666
info@cont-girbau.com
www.cont-girbau.com

Installation HS-6013/17 EH030/040



IMPORTANT SAFETY INSTRUCTIONS

WARNING: To reduce the risk of fire, electric shock or injury to persons when using the washer, follow basic precautions, including the following:

1. **READ** all instructions before using the washer and **KEEP** them in a prominent location for customer use.
2. Do not wash articles that have been previously cleaned in, washed in, soaked in, or spotted with gasoline, dry cleaning solvents, other flammable, or explosive substances as they **GIVE OFF VAPORS** that could ignite or explode.
3. **DO NOT ADD** gasoline, dry-cleaning solvents, or other flammable, or explosive substances to the wash water. These substances give off vapors that could ignite or explode.
4. Under certain conditions, hydrogen gas may be produced in a hot water system that has not been used for two weeks or more. **HYDROGEN GAS IS EXPLOSIVE.** If the hot water system has not been used for such a period, before using the washing machine, turn on all hot water faucets and let the water flow from each for several minutes. This will release any accumulated hydrogen gas. As the gas is flammable, do not smoke or use an open flame during this time.
5. Do not allow children to play on or in the washer. **CLOSE SUPERVISION** of children is necessary when the washer is used near children.
6. Before the washer is removed from service or discarded, **REMOVE** the door.
7. **DO NOT TRY TO OPEN THE WASHER'S DOOR** if the drum is moving.
8. Do not install or store the washer where it will be exposed to the **WEATHER.**
9. **DO NOT TAMPER** with controls.
10. **DO NOT REPAIR OR REPLACE** any part of the washer or attempt any servicing, unless specifically recommended in the user instructions or in published user-repair instructions that you understand and have the skills to carry out.
11. **DO NOT BY-PASS** any safety device. It is **NOT ACCEPTED ANY** electric or mechanic **MODIFICATION OR MANIPULATION. DO NOT INSTALL** foreign components inside the machine.
12. All **SAFETY INSTRUCTIONS** included in the Instruction Handbooks, should be reprinted and posted in the laundry room.
13. Failure to install and operate this machine according to the Instruction Handbooks or to work safety and hygiene standards and common sense, may result in conditions which **CAN PRODUCE** bodily injury or loss of life.
14. The **DANGER, WARNING, CAUTION** and **IMPORTANT** instructions appearing in the Instruction Handbooks are not meant to cover all possible conditions and situations that may occur. It must be understood that common sense, caution and carefulness are factors which cannot be built into this machine. These factors **MUST BE** supplied by the person(s) transporting, installing, maintaining, or operating the machine.
15. All connections for electrical power and plumbing **MUST** comply with the statutory safety standards applicable to each country, and be made by Licensed Installers only (*refer to note 3*).

16.  **WARNING!**
MACHINE INSPECTION, FILTER CLEANING, MAINTENANCE, SERVICE OR PARTS REPLACEMENT.
Before attempting any service or inspection of the washing machine:
Close and mechanically interlock the water supply valves and check that machine has **COMPLETELY** drained, parts have cooled down and that no pieces are in movement through inertia.
To reduce the risk of electrical shock:
- **COMPLETELY** disconnect the machine from the original power source and check for accidental reconnection. **MOVING THE ON SWITCH TO THE OFF POSITION IS NOT SUFFICIENT.**
 - Disconnect the electrical power of the external dosing to the washing machine. These circuits are independent of the washer's supply.
 - Wait a minimum of (5) five minutes after disconnection to ensure the elimination of residual voltage within the machine.
- Failure to comply with this warning may result in serious injury.**

17. **NEVER** operate the machine without the panels and guards correctly in place and secured.
18. The room **SHALL** comply with the environment conditions (air venting, temperature, humidity...) specified in the Installation Instruction Handbook. **NEVER INSTALL THE WASHING MACHINE** in very humid environments or with water splashes.
19. **DO NOT OPERATE** the machine if it is suspected to be faulty, either visually, by noise or smell, or with missing or broken parts.
20. Machine start-up **SHALL** be made by Authorised Service Technicians (*refer to note 2*).
21. Machine **SHALL BE USED** by qualified personnel (*refer to note 1*), wholly familiar with the machine's operation.
22. **DO NOT** allow children or people with handicaps incompatible to machine use to operate machine.
23. To minimise the possibility of creating a fire, take **SPECIAL** care, **KEEP** appliance area free from combustible materials and fire extinguishers should be easily **ACCESSIBLE** to all laundry staff.
24. Delimitate danger areas and **PREVENT** public access to them with machine in operation.
25. On completion of the day's work, **TURN OFF** the manual supply valves and **DISCONNECT** the electrical power by the External Automatic Switch.
26. Always **CONTACT** an Authorised Service Technician or Licensed Installer (*refer to notes 2 & 3*) about any problems or conditions you do not understand.
27. For a safe operation, machine **MUST** be kept in a good environment, used and maintained properly, and serviced annually by Authorised Service Technicians (*refer to note 2*).
28. The Distributor (seller) **IS OBLIGED** to thoroughly train the operator during the starting-up.

THE MANUFACTURER REFUSES ANY RESPONSIBILITY IF THESE SAFETY INSTRUCTIONS AND ALL INFORMATION IN THE CORRESPONDING HANDBOOKS ARE NOT FOLLOWED.

SAVE THESE INSTRUCTIONS

NOTES:

- (1) **Qualified Personnel** refers to anyone who has read the Instructions Handbooks, has been trained and has a thorough understanding of the machine's operation
- (2) An **Authorised Service Technician (AST)** is one that has successfully completed training on the product by Girbau S.A., or a Girbau, S.A. Distributor.
- (3) An **Authorised Licensed Installer** is one that is suitably qualified in the procedures and regulations applicable in that country.

HAZARD SYMBOLS USED ON WASHER LABELS:

**Electric risk**

Protection guard for electric components.

**High temperature risk.**

Operate with caution.
Use appropriate protections.

**Mechanical risk**

Protection guard for moving parts

**Risk of harmful vapours inhalation.**

Keep dispenser box closed.
Use appropriate protections.

SYMBOLS USED IN THIS MANUAL



This symbol alerts you to potential hazards for the user, the machine or the fabric.



This symbol is used to give relevance to any precise explanation

IMPORTANT INSTRUCTIONS FOR USE AND CONSERVATION

1. **EXPECTED MACHINE USE AND DON'TS.** This machine has been made and designed for washing or cleansing in a water bath, linen and textile materials without solvent impregnation or explosives. Unless approved by the manufacturer in writing, it is not considered appropriate **FOR OTHER PROCESSES**.
2. Machine **MATERIALS** in contact with wash products are:
 - Stainless Steel **AISI-304 L**.
 - Polypropylene **PP**.
 - **EPDM** and **NBR**.
 - Borosilicate glass.The chemicals furnisher and the machine owner will be responsible to assure that the products **ARE COMPATIBLE** and will not produce machine oxidation or damage.
Notice that the hypochlorite (bleach), in certain conditions of use, generates chlorine gas.
The chlorine is a corrosive and oxidizing substance that, in elevated concentrations and temperature, deteriorates the stainless steel and elastomers.
There are other highly oxidizing agents, such as the ozone, that can cause the same effect.
3. Periodically **CLEAN** machine, to prevent metallic parts corrosion, to produce higher output and for a longer life. To clean the washing machine, use water and detergent, rinse with a damp cloth, and dry.
4. **NEVER** use harsh products to clean the machine and laundry room. There are products on the market, which are highly corrosive.
5. If machine is left idle for long periods of time, it must be **PROTECTED** from humidity and temperature variations.
6. **FOLLOW** the fabric care instructions supplied by the manufacturer, **GIRBAU S.A., REFUSES ANY RESPONSIBILITY IN CASE OF TEXTILE WEAR AND TEAR.**
7. Failure due to improper machine operation may **VOID WARRANTY.**
8. Replacing any part of the washer can affect the machine's security.
Examples:
 - Just a screw or bolt of insufficient strength could cause dangerous damage.
 - A heater without an internal fuse could provoke a fire.
 - An inadequate clamp can be the cause of water leaks and short circuits... etc.The reason for which **ONLY ORIGINAL GIRBAU SPARE PARTS MUST BE USED.**

The incomppliance of this precaution may result in a washer breakdown, a serious accident, and loss of the warranty.
9. When asking for information on your machine, **MENTION** model and serial number (serial plate is located at the rear side).
10. **THE ELECTRICAL DIAGRAM IS LOCATED IN THE UNDERSIDE OF THE WASHER'S TOP COVER.**

SAFETY INSTRUCTIONS	2
INDEX	6
1. TECHNICAL SPECIFICATIONS	7
1.1. Tools needed for installation	7
1.2. Standards	7
1.3. Accessories in machine	7
1.4. Installation specifications	8
1.5. Connection table explanation	10
1.6. Electrical requirements	11
2. TRANSPORT AND LOCATION	13
2.1. Transport of crated machines	13
2.2. Washer location. Conditions.....	13
2.3. Installing more than one washer	14
2.4. Removal of shipping braces	15
3. INSTALLATION	16
3.1. Drain	16
3.2. Water supply.....	17
3.3. Electrical requirements	18
3.3.1. Previous requirements	18
3.3.2. Installation characteristics	18
3.3.3. Machine electrical connection	19
3.4. Steam connection	20
3.5. External dosing (option).....	21
3.5.1. External dosing electrical connection	21
3.5.2. External dosing hoses connection	21
3.6. Initial start-up	22
3.7. Emergency stop in coin-op installations	22
3.8. Connection to central vending point	23
3.8.1. Electrical connection from the central vending point to the washer.....	23
3.8.2. Washer configuration	24

1. TECHNICAL SPECIFICATIONS

1.1 Tools needed for installation

- Shipping restraintsopen end wrench 11/16 in. (17mm).
- Shipping restraintstubular wrench 11/16 in. (17mm)
- Clampsnut driver 7mm
- Water inlet filtersopen end wrench 1-3/8 in. (34mm)
- Covers fixingopen end wrench 1/2 in. (13mm)
- Water inlet hosesslip-joint pliers or pipe wrench diam. 1-1/2 in. (35 mm).
- Covers fixingTORX T25 screwdriver
- Covers fixingTORX T20 screwdriver.
- Electrical connectionPhillips 2 screwdriver (#2)
- External dosing connectionslotted-head screwdriver 3mm
- Vending circuit connection.....slotted-head screwdriver 3mm & Philips 1 (#1)

1.2 Standards

Compliance with the safety standard for Industrial Laundry Machinery, EN ISO 10472:

- Electrical Control Design following standard EN-60204-1
- Electromagnetic Compatibility: compliance with standard EN 61000-6-1; EN 61000-6-3; EN 61000-3-11.

1.3 Accessories in machine

Keep all machine instructions in a safe place.

ACCESSORIES	QUANTITY	NOTES
Drain hose	1 (2)	(1) not available USA / Canada
Drain clamp.....	1 (2)	(2) machines with dual drain: 2 pieces
Cold water inlet hose (1)	1	(3) machines with third water inlet: 2 pieces
Hot water inlet hose (1)	1 (3)	(4) machines with third water inlet: 3 pieces
Water inlet coupling	2 (4)	(5) machines with third water inlet: 9 pieces
Water inlet filter.....	2 (4)	(6) steam heating machines
Water inlet hoses gaskets	6 (5)	(7) only machines in USA / Canada with steam heating
Steam inlet filter and valve (6)	1	(8) Coin Control models only
Water inlet coupling (7)	1	(9) depending on target country
Top cover key	1	
Coin meter box key (8) (9)	1	
Tokens (8) (9)	10	
Fuse.....	1 x 10A	
Fuse	3 x 1A	
Installation handbook.....	1	
Operation handbook	1	
Parts handbook (1)	1	
Documentation	(9)	

1.4. Installation specifications

General specifications

	UNITS	HS-6013 / EH030	HS-6017 / EH040
DRY LINEN CAPACITY	kg 1/10 (lbs.)	12.6 (28)	17.3 (38)
SPIN	r.p.m.	600 / 1005	550 / 950
	G factor	125 / 351	119 / 354
WASHING SPEED (max)	r.p.m.	46.5	44
STATIC FORCE TRANSMITTED	kg (lbs.)	409 (902)	561 (1237)
DYNAMIC FORCE TRANSMITTED	kg (lbs.)	91 (201)	96 (212)
FREQUENCY OF THE DYNAMIC FORCE	Hz	16.7	15.8
KINETIC ENERGY	kJ	25.99	37.97
MAXIMUM SOUND LEVEL	dbA	< 70	< 70
PROTECTION INDEX	IP	21C	21C

Dimensions & weights

WITH CRATING	H	mm (inch.)	1485 (58.5)	1565 (61.6)	
	L	mm (inch.)	823 (32.4)	897 (35.3)	
	P	mm (inch.)	945 (37.2)	1017 (40)	
	WEIGHT	kg (lbs.)	372 (820)	495 (1091)	
WITHOUT CRATING	H	mm (inch.)	1325 (52.2)	1404 (55.3)	
	L	mm (inch.)	796 (31.3)	868 (34.2)	
	P	mm (inch.)	887 (34.9)	962 (37.9)	
	M	mm (inch.)	509 (20)	515 (20.3)	
		CdG K	mm (inch.)	540 (21.3)	567(22.3)
		CdG J	mm (inch.)	380 (15.0)	407 (16)
	WEIGHT	kg (lbs.)	344 (758)	476 (1049)	

Connections

A	CONNECTION	B.S.P thread (NH)	2 x 3/4 * 1	2 x 3/4 * 1
	H	mm (inch.)	1141 (44.9)	1232 (48.5)
	MIN/MAX PRESSURE	bar (P.S.I)	0.5-6 (7-87)	0.5-6 (7-87)
	RECOMMENDED PRESSURE	bar (P.S.I)	2-4 (30-60)	2-4 (30-60)
	FLOW (4 bar)	l/min (Usgal/min.)	60 (16)	60 (16)
	MAXIMUM TEMPERATURE	°C (°F)	80 (176)	80 (176)
D	OUTLET HOSE	∅ mm (inch.)	70 (3)	70 (3)
	H	mm (inch.)	125 (4.9)	125 (4.9)
	N	mm (inch.)	132 (5.2)	154 (6.1)
	P	mm (inch.)	250 (10)	250 (10)
	DRAIN BOX DIMENSIONS (L,P,H)	mm inch.	300 x 300 x 250 (H) 12" x 12" x 10" (H)	300 x 300 x 250 (H) 12" x 12" x 10" (H)
	DRAIN BOX PIPE	∅ mm (inch.)	100 (4)	100 (4)
E	INLET FASTENING	∅ mm (inch.)	37 (1 1/2)	37 (1 1/2)
	H	mm (inch.)	1005 (39.5)	1165 (45.9)
	N	mm (inch.)	326 (12.8)	360 (14.2)
Ed	INLET FASTENING	∅ mm (inch.)	16 (0.6)	16 (0.6)
	H	mm (inch.)	1005 (39.5)	1120 (44.1)
	N	mm (inch.)	226 (10.5)	367 (14.5)
	MAXIMUM VOLTAGE	V	240	240
	MAXIMUM CURRENT	A	1	1
d	CONNECTION	mm (inch.)	10 (3/8)	10 (3/8)
	H	mm (inch.)	1019 (40.1)	1100 (43.3)
	N	mm (inch.)	304 (11.9)	340 (13.4)
V	CONNECTION	B.S.P thread (inch.)	1/2	1/2
	H	mm (inch.)	625 (24.6)	626 (24.6)
	N	mm (inch.)	342 (13.4)	384 (15.1)
	PRESSURE	bar (P.S.I)	2/6 (29/87)	2/6 (29/87)
	FLOW	kg/h (lbs/h.)	80 (176)	80 (176)
Vc	INLET FASTENING	∅ mm (inch.)	16 (0.6)	16 (0.6)
	H	mm (inch.)	1005 (39.5)	1120 (44.1)
	N	mm (inch.)	226 (10.5)	367 (14.5)

Legend

CONNECTIONS	
A	Water inlets
D	Drain
E	Electrical connection inlet
Ed	Electrical connection inlet external dosing
d	Product inlets external dosing
V	Steam inlet connection
*1	INTELI CONTROL: option 3 x 3/4 inch.
Vc	Vending connection inlet (not applicable to USA/CANADA models)

DIMENSIONS (figures 1, 2,)	
H	Height from the machine base
N	Distance from the centre of symmetry of the unit
P	Depth
M	Height to door bottom
	Gravity centre (GC)

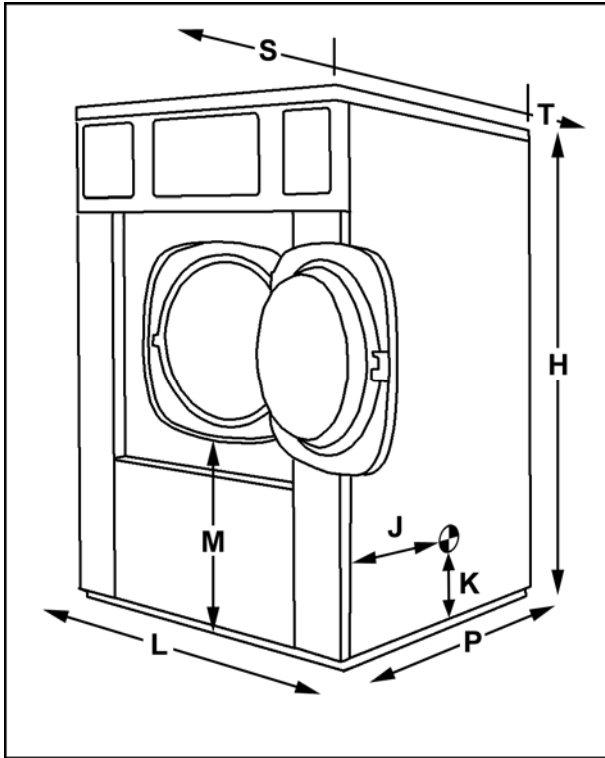

fig. 1

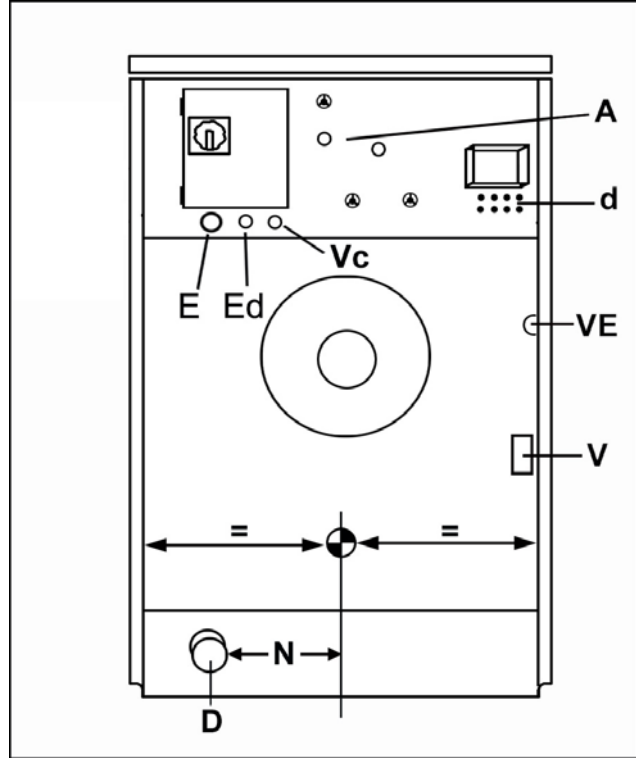

fig. 2

Environment and positioning conditions

MAXIMUM TEMPERATURA	°C (°F)	+41 (+104)
MINIMUM TEMPERATURE	°C (°F)	+5 (+40)
LIGHTING	Lux	300
VENTING OPENING	cm ² (sq.ft.)	300 (0.4)
MAXIMUM RELATIVE HUMIDITY	%	90
S	WORKING AREA	mm (inch.)
T	REAR MAINTENANCE AREA	mm (inch.)
		1000 (39.4)
		500 (19.7)

If the installation calls for more than one washer, refer to additional dimensions in section 2.3 and figure 3.

1.5. Connection table explanation

Connection table explanation and symbols of section 1.6

(*1) HEATING	
H	Without heating
E	Electric heating Consult TOTAL ELECTRICAL POWER in the nameplate
V	Steam heating

(*2) EXPLANATION OF CONNECTION VALUES	
A x B + N +	Wire details in mm ²
(A x B + GND)	(USA/CANADA: wire details in AWG)
A x B + N +	Wire number
A x B + N +	Neutral wire
A x B + N +	Ground
(A x B + GND)	(USA/CANADA: ground)
USE COPPER CONDUCTORS ONLY	

1.6. Electrical requirements



Check table explanation in section 1.5.



In brackets: USA / CANADA specific values

HS-6013 / EH030

VOLTAGE	HEATING (*1)	TOTAL POWER	TOTAL CONSUMP.	SWITCH CURRENT	WIRE DETAILS (*2)
		kW	A	A	mm ² (AWG)
200V 1ph + N	H/V	0.87	4.4	6	1,5 x 2 +
	E	5.0	24.8	32	6 x 2 +
		6.5	32.3	40	10 x 2 +
208V 1ph + N	H/V	0.87	4.2	6	1,5 x 2 +
		(0.87)	(4.2)	(6)	(16 x 2 + GND)
	E	5,3	25.6	32	6 x 2 +
		7.0	33.5	40	10 x 2 +
		(6.4)	(30,9)	(40)	(6 x 2 + GND)
220V 1ph + N	H/V	0.87	4.0	6	1,5 x 2 +
	E	5.9	26.9	40	6 x 2 +
		7.7	35.2	50	10 x 2 +
230V 1ph + N	H/V	0.87	3.8	6	1,5 x 2 +
	E	6,4	27.9	40	6 x 2 +
		8.4	36.6	50	10 x 2 +
240V 1ph + N	H/V	0.87	3.6	6	1,5 x 2 +
		(0.87)	(3.6)	(6)	(16 x 2 + GND)
	E	6,4	26.8	40	6 x 2 +
		8.4	35.1	50	10 x 2 +
		(8.4)	(35.1)	(50)	(6 x 2 + GND)
200V 3ph	E	7,2	21.7	32	6 x 3 +
		9.5	28.3	40	6 x 3 +
208V 3ph	E	7.8	22.5	32	6 x 3 +
		10.2	29.3	40	6 x 3 +
		(9.4)	(27.0)	(40)	(8 x 3 + GND)
220V 3ph	E	8,7	23.5	32	6 x 3 +
		11,4	30.7	40	6 x 3 +
230V 3ph	E	9,4	24.4	32	6 x 3 +
		12.4	31.9	40	6 x 3 +
240V 3ph	E	9,4	23.4	32	6 x 3 +
		12.4	30.6	40	6 x 3 +
		(12.4)	(30.6)	(40)	(8 x 3 + GND)
380V 3ph + N	E	8,6	14.4	20	4 x 3 + N +
		11.3	18.5	25	4 x 3 + N +
400V 3ph + N	E	9,5	14.9	20	4 x 3 + N +
		12.5	19.3	25	4 x 3 + N +
415V 3ph + N	E	9,4	14.2	20	4 x 3 + N +
		12.4	18.4	25	4 x 3 + N +



Check table explanation in section 1.5.



In brackets: USA / CANADA specific values

HS-6017 / EH040

VOLTAGE	HEATING (*1)	TOTAL POWER	TOTAL CONSUMP.	SWITCH CURRENT	WIRE DETAILS (*2)
		kW	A	A	mm ² (AWG)
200V 1ph + N	H/V	1,3	6,5	10	1,5 x 2 +
	E	5,2	25,8	32	6 x 2 +
		8,2	40,9	50	10 x 2 +
208V 1ph + N	H/V	1,3	6,3	10	1,5 x 2 +
		(1,3)	(6,3)	(10)	(16 x 2 + GND)
	E	5,5	26,6	32	6 x 2 +
		8,8	42,3	50	10 x 2 +
(8,1)	(39,1)	(45)	(6 x 2 + GND)		
220V 1ph + N	H/V	1,3	5,9	10	1,5 x 2 +
	E	6,1	27,8	40	6 x 2 +
		9,8	44,4	63	10 x 2 +
230V 1ph + N	H/V	1,3	5,7	10	1,5 x 2 +
	E	6,6	28,8	40	6 x 2 +
		10,6	46,2	63	10 x 2 +
240V 1ph + N	H/V	1,3	5,4	10	1,5 x 2 +
		(1,3)	(5,4)	(10)	(16 x 2 + GND)
	E	6,6	27,6	40	6 x 2 +
		10,6	44,3	63	10 x 2 +
(10,6)	(44,3)	(60)	(6 x 2 + GND)		
200V 3ph	E	7,4	22,7	32	6 x 3 +
		12,0	35,8	50	10 x 3 +
208V 3ph	E	8,0	23,4	32	6 x 3 +
		12,9	37,0	50	10 x 3 +
		(11,9)	(34,3)	(40)	(6 x 3 + GND)
220V 3ph	E	8,9	24,4	32	6 x 3 +
		14,3	38,8	50	10 x 3 +
230V 3ph	E	9,6	25,3	32	6 x 3 +
		15,6	40,3	50	10 x 3 +
240V 3ph	E	9,6	24,2	32	6 x 3 +
		15,6	38,7	50	10 x 3 +
		(15,6)	(38,7)	(50)	(6 x 3 + GND)
380V 3ph + N	E	8,8	15,3	20	4 x 3 + N +
		14,3	23,6	32	6 x 3 + N +
400V 3ph + N	E	9,7	15,8	20	4 x 3 + N +
		15,7	24,5	32	6 x 3 + N +
415V 3ph + N	E	9,6	15,1	20	4 x 3 + N +
		15,6	23,4	32	6 x 3 + N +

2. TRANSPORT AND LOCATION

2.1 Transport of crated machines



ALWAYS USE TRANSPORT METHODS WHICH ARE SUITABLE FOR THE WEIGHT AND VOLUME OF THE WASHER. CHECK THE VALUES ON THE PACKAGING AND THE INSTALLATION SPECS (section 1.4) OF THIS MANUAL.

- Before moving the washer, check the instructions of the packaging pictograms.
- Unit must be transported in the upright position.
- Protect the machine from rain and dampness
- Avoid blows and shocks.
- It is preferable to transport the washer with its packaging using a forklift and by lifting it from its base. Never move the machine by pushing on the sides of the packaging.
- Position the washer with crating as near as possible to the final location.

2.2 Washer location. Conditions.



INSTALLATION ON UPPER FLOORS.

Do not install the machines on suspended floors or above ground level without obtaining approval from the appropriate qualified technician (structural engineer for building safety and noise transmission).

See floor static & dynamic strength requirements on INSTALLATION SPECIFICATIONS (section 1.4). The manufacturer refuses any responsibility for damage (caused by the vibrations) to the building structure in these cases.

The floor of the washer location must be a flat surface (refer to the indications on the INSTALLATION SPECS, section 1.4)

Respect the **ENVIRONMENTAL CONDITIONS** indicated on the INSTALLATION SPECS (section 1.4 and 2.3). Also, respect the work and maintenance areas; these are necessary for the safe use and appropriate maintenance of the washing machine.

Do not install the washer in improper vented areas. The products used can produce steam and gas products emissions, which in high concentrations can be very dangerous to health.

TO REDUCE VIBRATION AND SOUND AND TO ENSURE THAT THE MACHINE IS CORRECTLY BALANCED, IT IS ESSENTIAL THAT THE FOUR BASE LEGS OF THE WASHING MACHINE REST UNIFORMLY UPON THE FLOOR. DO NOT PLACE ANY TYPE OF ANTI-VIBRATORY DEVICE BETWEEN THE WASHER AND THE FLOOR.

NEVER INSTALL THE WASHER OVER AREAS BUILT WITH COMBUSTIBLE MATERIAL. IF WASHERS ARE INSTALLED ON METALLIC SURFACES, AN ELECTRICAL CONDUCTOR INDEPENDENT TO THE WASHER GROUND MUST GROUND THESE SURFACES.



Specific warning for appliances installed IN THE USA /CANADA.

To reduce the risk of fire, this appliance must be fastened or otherwise secured to an uncovered concrete floor.

2.3. Installing more than one washer.

If the installation calls for more than one washer, align them with each other.

The minimum distance between adjacent machines and the user and maintenance areas (values **I**, **S** and **T** of **figure 3**) are specified on the table below.

Check the dimensions of the drain box and the drain pipe on the table below.

Location conditions (fig. 3)

I	DISTANCE BETWEEN MACHINES (RECOMMENDED) (Commercial and Industrial laundries)	mm (inch.)	100 - 250 (4 - 10)
	DISTANCE BETWEEN MACHINES (MINIMUM) (Coin-op laundries)	mm (inch.)	10 (0.4)
S	WORKING AREA	mm (inch.)	1000 (39.4)
T	REAR MAINTENANCE AREA	mm (inch.)	500 (19.7)
A	DRAIN BOX	mm inch.	300 x 300 x 250 (H) 12" x 12" x 10" (H)
\emptyset	DRAIN PIPE (\emptyset x1; \emptyset x2; \emptyset x3)	\emptyset mm (inch.)	100; 150; 180 (4; 6; 7)

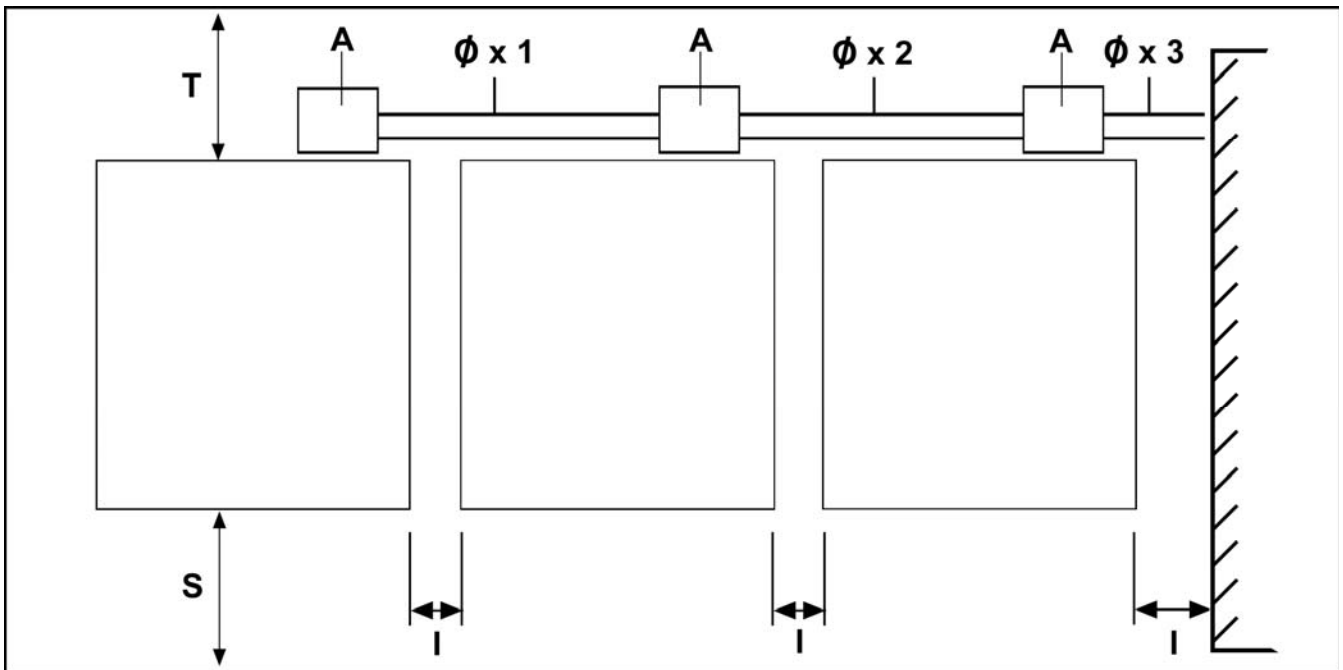

fig. 3

2.4 Removal of shipping braces



DO NOT REMOVE THE SHIPPING RESTRAINTS BEFORE PLACING THE WASHER IN ITS DEFINITIVE POSITION.

NEVER START THE MACHINE UP WITHOUT FIRST REMOVING THE SHIPPING RESTRAINTS. INCOMPLIANCE WITH THIS PRECAUTION MAY CAUSE SERIOUS PHYSICAL DAMAGES TO PEOPLE AND IRREPARABLE DAMAGES TO THE WASHER. THE WARRANTY DOES NOT COVER THIS INCIDENT.

How to proceed (fig. 4 & 5).

- Disassemble the lower cover **A**, by removing screws **B**
- Remove the two yellow pieces **C** by removing screws **D**.
- Assemble the lower cover and fasten the toe plate with screws **B**
- Disassemble the centre rear cover.
- Remove the two yellow pieces **E** by removing screws **F**.
- **On machines with steam heating**, cut the fastening clip of the electrovalve coil; pull back the coil towards the machine exterior and fasten the coupling for the electrical installation to cut out **VE** on the rear cover (*refer to fig. 2*).
- Assemble the rear cover and secure with the corresponding screws.
- Save the shipping braces. If the washer ever needs to be moved to another location, replace the transport system reversing the steps described in this section.

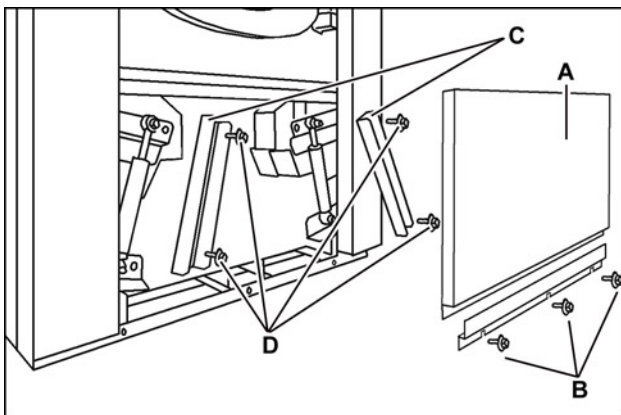

fig. 4

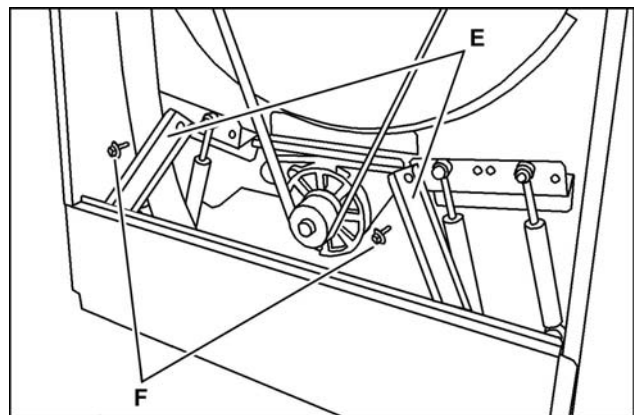

fig. 5

3. INSTALLATION



ALL CONNECTIONS FOR ELECTRICAL POWER AND PLUMBING MUST COMPLY WITH THE STATUTORY SAFETY STANDARDS APPLICABLE TO EACH COUNTRY, AND BE MADE BY LICENSED INSTALLERS ONLY.

3.1. Drain

Drain to the drain box. (Most recommended option)

Build a drain box (**fig. 6**) following the specifications indicated in the INSTALLATION SPECS, section 1.4. Connect the drain elbow to the drain outlet and secure hose with the corresponding clamp (**fig. 7**).

Do not sink the free end of the drain elbow in the drain box:

- To prevent dirty water siphoning to the washing machine.
- To facilitate the water drain.
- To detect water leaks through the drain
- To prevent dirty water from coming into contact with the washer.

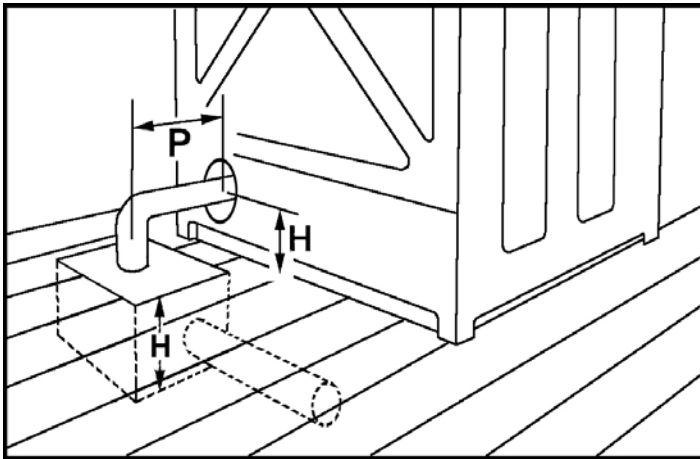

fig 6

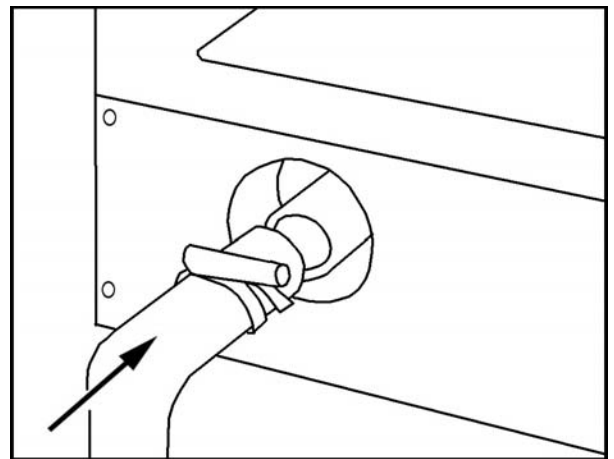

fig. 7

Direct connection of the washer drain to the sewer (fig.8).

Facilities preferring this option to the open box option (recommended option) must respect the following precautions:

Provide next to the connection point of each machine to the sewer, with a sewer ventilation pipe **A** reaching the outside, set at a height of 40 inch. (1000 mm) and 50mm (2 inch) diameter.

Drain trap diameter **B**: refer to table on section 2.3. and **figure 3**.

The emptying of the drain trap to the sewer system is done through an open drain box (**fig. 8/B** and **C**) which prevents variations in pressure and backflow to the drain. **The end of the drain trap must not be sunk in the box.**

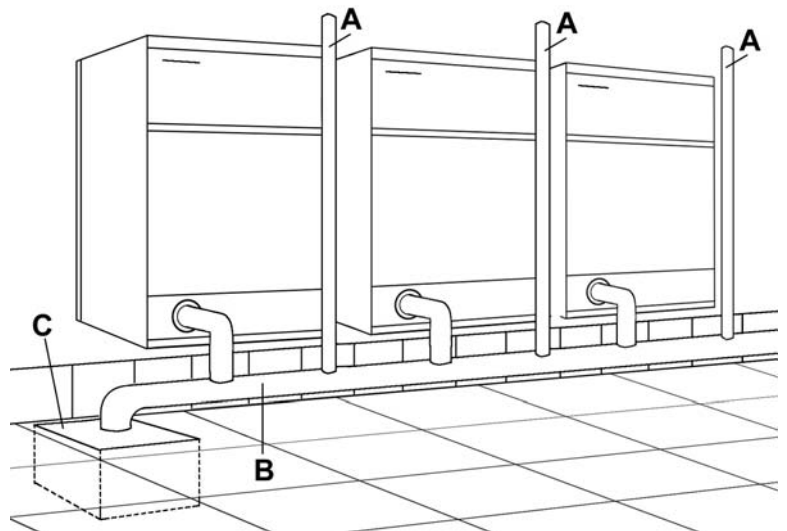

fig. 8

3.2. Water supply

Hoses and pipes should be flushed through before being connected to the machine.

Install at each water supply and in an accessible location, a mechanically interlocked water valve.

Refer to technical specifications on the INSTALLATION SPECS, section 1.4

Assembling the filters and their connection (fig. 9)

Insert filter **C** and washer **B** inside each of the water inlet couplings **D**

Assemble the couplings to the electrovalves **A**.

Place the **E** seals on the water inlet hoses **F**.

Put the water inlet hoses on the electrovalve couplings.

Open the manual valves and check for leaks in the installation.

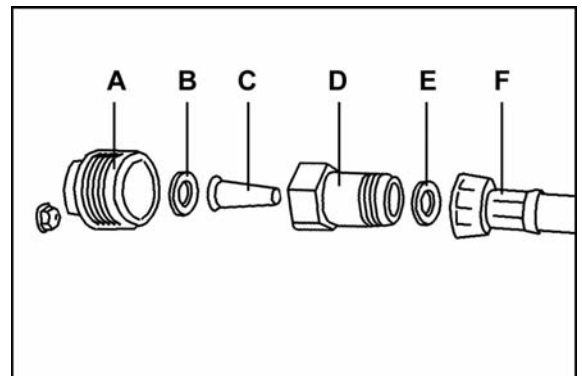



fig. 9

Arrangement of the hoses

The inlets are identified by the label posted at each inlet (fig. 10).

The washer mixes hot and cold water according to the temperature programmed. The use of hot/cold water allows the machine to gain time and effectiveness in its washing programs.

Inlet 1.  The cold water must **ALWAYS** be connected. The hose is marked with a blue line.

Inlet 2.  Connect hot water. This hose is marked with a red line.

Inlet 3.  (This option is only available for Inteli Control). Connect cold or hot water according to the washer configuration. The hose is marked with a red line.

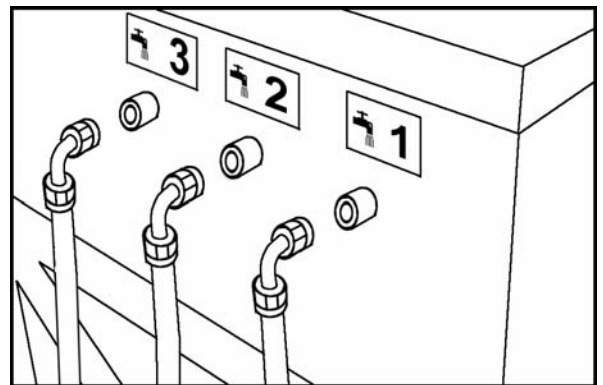

fig. 10



DO NOT CONNECT THE HOT WATER TO INLET 1. THIS INLET DOES NOT HAVE A TEMPERATURE CONTROL SYSTEM.

DO NOT CONNECT THE HOT WATER TO INLET 3 IF IT IS NOT CONFIGURED AS A DUAL HOT WATER INLET FLOW.

INCOMPLIANCE OF THIS PRECAUTION CAN CAUSE FABRIC DAMAGE.



If there is no hot water supply, connect cold water or cold softened water to inlet 2.

INTELI control washing machines, ADAPT THE WASHER CONFIGURATION to operate with cold water.

3.3. Electrical requirements

3.3.1. Previous requirements



CHECK THAT THE POWER AND FREQUENCY OF THE ELECTRICAL SUPPLY CORRESPONDS TO THOSE OF THE WASHER. Check the nameplate posted on the back panel of the machine.



ALL CONNECTIONS FOR ELECTRICAL SUPPLY MUST BE CARRIED OUT BY LICENSED ELECTRICIANS AND MUST COMPLY WITH THE STATUTORY SAFETY STANDARDS APPLICABLE TO EACH COUNTRY.



ALL THE MATERIALS USED IN THE ELECTRICAL INSTALLATION MUST COMPLY WITH THE STATUTORY SAFETY STANDARDS APPLICABLE TO EACH COUNTRY.



ALWAYS CONNECT THE GROUND EXTERNAL PROTECTION CIRCUIT. THIS UNIT MUST BE CONNECTED TO THE GROUND INSTALLATION WITH A CONDUCTOR CONNECTED TO THE EQUIPMENT GROUNDING TERMINAL.



Specific warning for appliances installed in USA/CANADA.

GROUNDING INSTRUCTION. This appliance must be connected to a grounded metal, permanent wiring system, or an equipment grounding conductor must be run with the circuit conductors and connected to the equipment grounding terminal on the appliance.

3.3.2. Installation characteristics.

Check the specific characteristics on the ELECTRICAL CONNECTION table (section 1.5)

Conductor:

- The data referring to conductors are based on those of a copper multi-wire conductor.
- The length of the conductor from the safety switch to the washer must not be longer than 30ft (10m).
- If using single-wire conductors, these must be encased within a safety conduit.
- The conductor must be affixed to the inlet opening of the machine using a secure connection appropriate for the type of conductor or safety conduit.
- The conductor must be secured against any pulling, crushing or rubbing.
- Other conductor specifications: it must concur with the normative of the country of installation.

Circuit breaker. Install an earth-leakage protected circuit breaker.

Characteristics:

- Installed in an easily accessible place.
- number of poles and intensity: consult ELECTRICAL CONNECTION table (section 1.5)
- A type.
- protected against pulse currents, harmonics, the presence of continuous components... (consult manufacturer specifications)

Safety switch. Install an Automatic on/off Switch, outside the washer, with individual protection for each machine.

Characteristics:





- number of poles and intensity: consult ELECTRICAL CONNECTION table (section 1.5)
- C type with top opening at 3 mm. (0.12 inch.)
- Must isolate electrical source phases and the N cable.
- Mechanically lockable.
- Installed in an easily accessible place.

3.3.3. Machine electrical connection

- Disconnect and mechanically lock the external automatic switch.
- Open machine terminal box at the rear panel. Remove the support cover of the entry switch to the washer.
- On the entry hole of the electrical supply (**E** identified in figure **2**) install a lock mechanism (not supplied with the washer) to fasten the cable or cable pipe protector. Refer to dimensions and connection diameter in **INSTALLATION SPECS**, section **1.4**.
- Connect the wires directly to the switch breaker.
- The wire connection sequence to the main switch varies according to the machine connection and the power supply. This connection is indicated on the label posted next to the main switch.

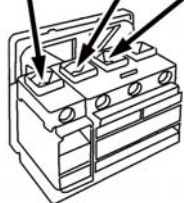
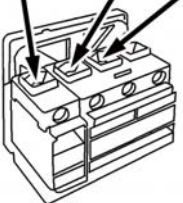
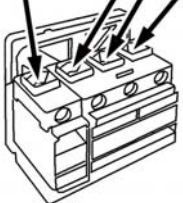
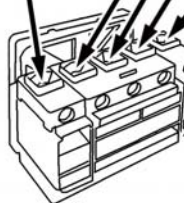

FOR A CORRECT CONNECTION, FOLLOW THE INDICATIONS LISTED IN THE TABLE BELOW

LABEL	PE/GND L1 L2/N	PE/GND L1 L2/N	PE/GND L1 L2 L3	PE/GND L1 L2 L3 N
POWER SUPPLY	 L1 L2	 L1 N	 L1 L2 L3	 L1 L2 L3 N
CONNECTION	PE/GND - L1 - L2 	PE/GND - L1 - N 	PE/GND-L1-L2-L3 	PE/GND-L1-L2-L3-N 

3.4. Steam connection.

In some models the body of the steam electrovalve and the filter are shipped inside the drum of the washing machine, separate from the electrical wiring system. The coil is connected to the end of the electrical installation.

In other models, the assembly electrovalve and filter are supplied connected to the electrical wiring system.

Installation characteristics

Before connecting the installation to the electrovalve, purge the pipe conduits.

Place a mechanically lockable flow valve in the steam inlet in an accessible place.

Check dimensions and connection diameters in the Installation specs (section 1.4).

Assembly and electrovalve connection



SEAL ALL THREADED UNIONS WITH A PRODUCT WHICH IS APPROPRIATE FOR STEAM PIPE CONDUITS.

Respect the steam circulation direction indicated by an arrow on each part.

The coil has been previously removed from shipping position or disconnected from the electrovalve (according to shipping braces)

The electrical wiring must be fastened to the cut out **VE** on the rear cover (see **fig. 2** and section **2.4**).

Place the electrovalve on the end of the steam inlet pipe of the machine.

Machines in **USA/Canada**: place the small steam inlet hose (**fig. 11/A**) to the filter inlet.

Connect the steam supply of the installation to the washer inlet. Safeguard the installation against accidental contact. It is advisable to insulate the installation to prevent heat loss.

Place the coil on the electrovalve body and fasten it with the core end screw.

Open the manual valve and check for leaks in the installation.

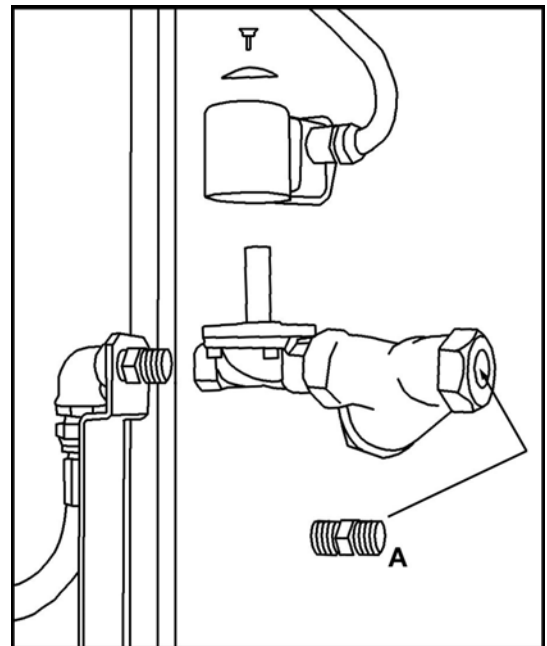

fig. 11

3.5. External dosing (option)

This machine can control external dispenser equipment by generating a signal able to activate the various inlets of the dispenser equipment.

These signals are made by closing a relay contact between the COMMON terminal and the outputs of each one of the various terminals coinciding with the different dosing made by the washing programs. The icons on the label indicate which output corresponds with each dispenser compartments.

The length of the signal has a fixed time (between 20 and 30 sec.) and can not be modified.

Consult electrical connection specifications in the INSTALLATION SPECS, section 1.4.

3.5.1. External dosing electrical connection

Signal conductor

- If using single-wire conductors, these must be encased within a safety conduit.
- The conductor must be affixed to the inlet opening of the machine using a secure connection appropriate for the type of conductor or safety conduit.
- The conductor must be secured against any pulling, crushing or rubbing.
- Other conductor specifications: it must concur with the normative of the country of installation.

Connection of the dispenser equipment to the washer (*fig. 12*).

- Disconnect and mechanically lock the external automatic switch.
- Open machine terminal box.
- On the entry hole of the external dosing electrical supply (**Ed** identified in figure 2) install a lock mechanism (not supplied with the washer) to fasten the cable or cable pipe protector. Refer to dimensions and connection diameter in INSTALLATION SPECS, section 1.4.
- Connect the dispenser signal cable to the terminal board **A**, according to the functions specified on the corresponding label. (This terminal board is identified on the electrical schematic as X-6)
- Connect the power supply of the dispenser equipment to an electrical inlet separate from the washer. The electrical protection of the dispenser equipment must be separate from the washer protection.

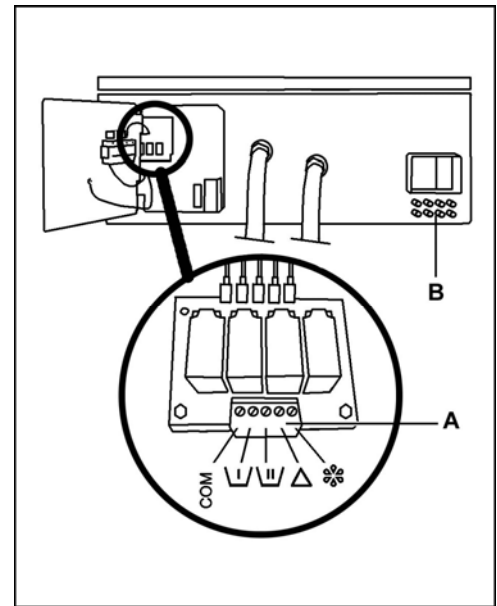

fig. 12



NEVER CONNECT THE DISPENSER EQUIPMENT SUPPLY TO THE WASHER.

- Inteli control washing machines and second input and output board (I/O2) option: refer to electrical schematic of the machine for more external dosing signals connection.

3.5.2. External dosing hoses connection

The external dosing inlets are perforated and protected by a tube cap.

Refer to dimensions and dosing inlets diameter in INSTALLATION SPECS, section 1.4.

To connect the product cables:

- Locate the dosing inlets in the back of the machine.
- Remove the tube caps and save them.
- Connect the hoses to the nipples **B** on the manifold (*fig. 12*).
- Fasten the dosing hoses to the washing machine with the appropriate clamps.

COIN CONTROL units:

To enable the external dosing system, you must modify the external dosing parameter at the MODIFICATION menu (see the Advanced Operation Instructions, for **HS-6 / EH COIN CONTROL** at the manufacturer's website: www.girbau.com)
(USA/CANADA www.cont-girbau.com)

3.6. Initial Start-up.

THE WASHER MUST BE PUT INTO SERVICE BY AN AUTHORIZED SERVICE TECHNICIAN.

Before the initial STARTING, make sure that you accomplish the following points:

- Remove all packaging materials (Break them down in order to appropriately recycle them)
- Remove all tools used during the installation.
- Verify that all accessories have been removed from the drum interior.
- Verify the correct installation of all the accessories necessary for the washer operation.
- Check that the electrical installation corresponds with the voltage and the frequency of the machine.
- Verify that the four washer feet come in contact with the floor.
- Verify that all the shipping restraints are removed.
- Connect all the water, steam (steam heated washers) and power inlets according to the technical specifications.
- Open the manual water inlet valves (and steam if necessary) and check for any leaks around the manual flow valves and connection couplings.
- Connect the electrical supply.
- Check the operation (it is recommended to use the TEST program).
- Keep the manual in a safe place and in good condition for its possible consultation.
- Before washing clothes for the first time we recommend to run a complete cycle with detergent (1/4 the normal recommended amount).

3.7. Emergency stop in coin-op installations

IN ACCORDANCE WITH SAFETY REQUIREMENTS FOR INDUSTRIAL MACHINERY Standard (UNE-EN ISO 10472-1,5-2) AND OTHER SAFETY REQUIREMENTS, THE LAUNDRY OWNER / USER IS RESPONSIBLE FOR INSTALLING A REMOTE LOCATED EMERGENCY STOP DEVICE, CONNECTED TO EACH MACHINE.

Device features

To be located in a visible place, separated from all machines and easily accessible.

To break the electrical supply for all machines.

To safely isolate all machines at maximum consumption.

To need reinstating (the whole installation) after the Emergency Stop Push-button has been unlocked.

3.8. Connection to central vending point (option only available in Coin Control models. Not applicable to models in the USA/CANADA)

It is possible to connect the washer to an external central vending point by means of an adaptation circuit installed inside the washer. This option allows payments to be made and the prices to be controlled entirely from the central vending point.

The adaptation circuit allows the **PROGRAM START** command to be received from the central vending point and at the same time, a relay contact informs the central vending point of the **AVAILABILITY OF THE WASHER** to start a wash cycle.

a) PROGRAM START command. Features.

The adaptation circuit is able to receive two signals or electrical impulses of different potentials from the central vending point. Each impulse detected by the circuit adaptor will decrease the value needed to start the wash cycle by one unit. When the total value has been accounted for, the washer will begin the wash cycle.

It must be pointed out that the Start Wash Program command can be overridden by pressing the **STOP** button on the washer's keyboard. Refer to the **PSH** parameter in the **Mod** menu in the Advanced Coin Control Instruction Manual on the manufacturer's Web: www.girbau.com.

Features and wiring for different inputs (see board A8 on electric circuit diagram)

- Alternating current signal: voltage between 115 and 230V. Connection terminals: X1-4 and X1-5.
- Direct current signal: voltage between 5 and 25V. Connection terminals: X1-7 and X1-8.

The minimum duration for these impulses will be 50ms (0.05 seconds).

The electrical features on the central vending point will determine the application of one or another electrical signal.

b) AVAILABILITY OF WASHER indicator. Features.

Free voltage contact. Maximum voltage: 250V.AC.

- Machine NOT AVAILABLE. Contacts closed between terminals C and NC (X1-1 and X1-2). Washer not in operation, door open, end of cycle or in the process of a wash cycle.
- Machine AVAILABLE. Contacts closed between terminals C and NO (X1-1 and X1-3). Washer ready to begin a wash cycle and door closed.

Making use of the AVAILABILITY indicator will depend on the central vending point's operating features.

3.8.1. Electrical connection from the central vending point to the washer

Signal conductor

- Features of the conductor: minimum section: 0.35mm²; minimum voltage: 250V.
- In the event that single wire conductors are used, they must be protected by a protection tube.
- The conductor must be fixed to the machine's inlet hole by means of a secure joint suitable for the type of conductor.
- The conductor must be protected against traction, crushing and friction.
- Additional specifications for the conductor: must comply with the statutory regulations of the country in which it is to be installed.

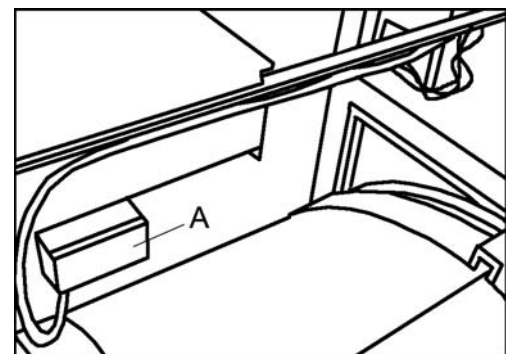

fig. 13

Connecting the central vending point to the washer

- Disconnect and mechanically lock the external automatic switch.
- Open the machine's top cover.
- Fix a conductor bracket (not supplied with the washer) to the inlet hole and secure the conductor in place. (**Vc** installation card, section 1.4. fig. 2).
- Open circuit adapter box cover **A**. This box is located on the side of the inverter box (**fig. 13**). Cut a hole in the inlet box protector to the size of the conductor to be used.

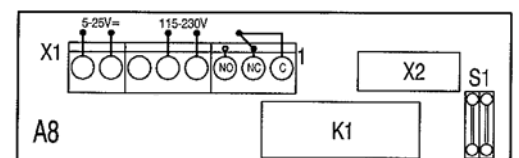

fig 14

- Connect the communication signal wires up to the vending circuit on to terminal strip **X1**, according to the instructions in the previous section (**fig. 14**). Close the circuit box.
- Position and lock the top cover in place. Connect the electricity supply.

3.8.2. Washer configuration

In washers connected to central vending points, the configuration for the token or coin meters (parameter **P**) should be configured as tokens (value **to**)

Refer to CONFIGURATION of COIN control in the Technical Assistance Manual on the manufacturer's Web: www.girbau.com.