

**ENGLISH**

- A1 CONTROL CIRCUIT
- A2 INVERTER
- A3 DC SOURCE
- A4 FUSES, DISPENSER 1 to 4
- B1 COIN DETECTOR -1
- B2 COIN DETECTOR -2
- F1-2(A4) CONTROL FUSES
- F4(A3) DC POWER SUPPLY FUSE
- F5 MOTOR THERM. PROTECTION
- F6 INVERTER FUSE
- KA1 INVERTER RELAY
- KA2(A4) PRE-WASH
- KA3(A4) WASH
- KA4(A4) BLEACH
- KA5(A4) SOFTENER
- KM1 HEATERS CONTACTOR
- H1 WATER LEVEL DETECTOR
- M1 WASH MOTOR
- M2 DRAIN
- M3 INVERTER FUN
- Q1 MAIN SWITCH
- R1 HEATERS
- R2 DOOR LOCK
- R3 TEMPERATURE PROBE
- S0 START-STOP (LC only)
- S1 EMERGENCY STOP (LC only)
- S2 UNBALANCE
- S3 MOTOR GND ( USA/CAN only)
- Y1 STEAM SELENOID
- Y2 ELECTROVALVULA VAPOR
- Y3-4 COLD WASH WATER SELENOID
- Y5-6 HOT WASH WATER SELENOID
- Y7 PREWASH & RINSES DISPENSER
- Y8 BLEACH DISPENSER
- Y9 SOFTENER DISPENSER
- COIN METER INTERLOCK

**ESPAÑOL**

- CIRCUITO MANDO
- INVERTER
- CIRCUITO CC
- FUSIBLES Y DOSIFICADOR 1 a 4
- DETECTOR MONEDAS -1
- DETECTOR MONEDAS -2
- FUSIBLES MANDO
- FUSIBLE CIRCUITO CC
- PROTECCION TERM. MOTOR
- FUSIBLE INVERTER
- RELE INVERTER
- PRELAVADO
- LAVADO
- BLANQUEANTE
- SUAVIZANTE
- CONTACTOR CALEFACTORES
- DETECTOR NIVEL BAÑO
- MOTOR LAVADO
- DESAGÜE
- VENTILADOR INVERTER
- INTERRUPTOR PRINCIPAL
- CALEFACTORES
- BLOQUEO PUERTA
- SONDA TEMPERATURA
- MARCHA-PARO ( Solo LC )
- PARO EMERGENCIA ( Solo LC )
- DESEQUILIBRIO
- TIERRA MOTOR (solo USA/CAN)
- ELECTROVALVULA VAPOR
- ELECTROVALVULA AGUA FRIA LAVADO
- ELECTROVALVULA AGUA CALIENTE LAVADO
- DOSIFICADOR PRELAVADO Y ACLARADOS
- DOSIFICADOR BLANQUEANTE
- DOSIFICADOR SUAVIZANTE
- BLOQUEO MONEDERO

**FRANCAIS**

- CIRCUIT COMMANDE
- INVERSEUR FREQUENCE
- CIRCUIT CC
- FUSSIBLES ET DOSSAGE 1 a 4
- DETECTEUR MONNAIES -1
- DETECTEUR MONNAIES -2
- FUSIBLES COMMANDE
- FUSIBLE CIRCUIT CC
- PROTECTION TERM. MOTEUR
- FUSIBLE INVERSEUR
- RELE INVERSEUR
- PRELAVAGE
- LAVAGE
- BLANQUISANT
- ADOUSSISANT
- CONTACTEUR CHAUFFAGE
- MOTEUR LAVAGE
- MOTEUR LAVAGE
- VIDANGE
- VENTILATEUR INVERSEUR
- INTERRUPTEUR PRINCIPALE
- ELEMENTS DE CHAUFFE
- VERROUILLAGE PORTE
- SONDE TEMPERATURE
- MARCHE-ARRÊT ( Seulement LC )
- ARRÊT URGENCE ( Seulement LC )
- DESEQUILIBRE
- TERRE MOTEUR (seulement USA/CAN)
- ELECTROVANNE VAPEUR
- ELECTROVANNE EAU FROIDE LAVAGE
- ELECTROVANNE EAU CHAUDE LAVAGE
- DOSSAGE PRELAVAGE ET RINÇAGES
- DOSSAGE BLANQUISANT
- DOSSAGE ADOUSSISANT
- VERROUILLAGE MONNAYEUR

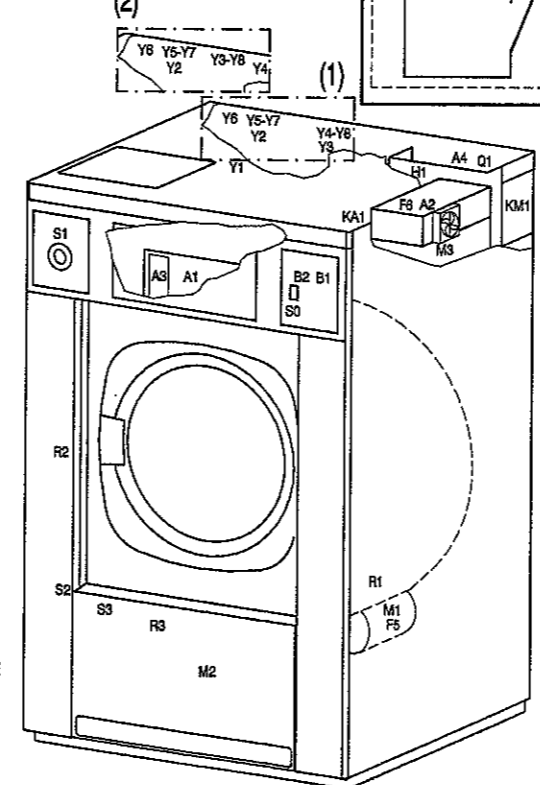

- (1) STANDARD OPTION
- (1) OPCION STANDARD
- (1) OPTION STANDARD
- (2) HIGH TEMPERATURE OPTION
- (2) OPCION ALTA TEMPERATURA
- (2) OPTION HAUTE TEMPERATURE

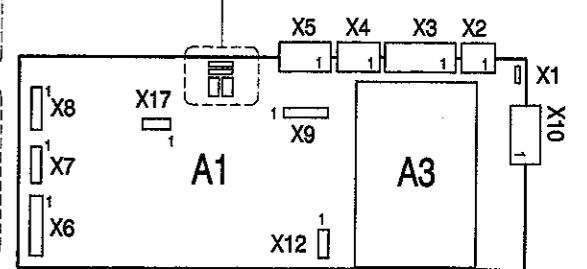
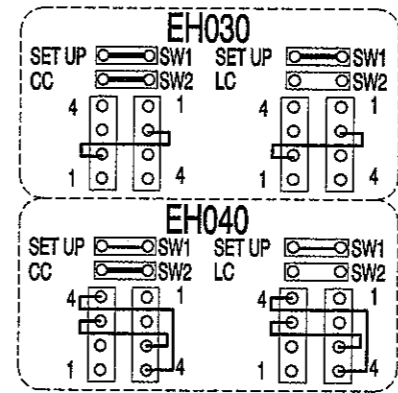

3	A. Mora	J. Alsina	21-12-05	I. Riera	4/1/06
2	A. Mora	J. Alsina	16-11-05	I. Riera	17-11-05
1	A. Mora	J. Alsina	27-05-05	I. Riera	12-7-05
0	A. Mora	J. Alsina	20-04-05	I. Riera	20-4-05
DIBUJ-PROY.		REVISADO		FECHA	
A1		A3		X12	
MODIFIC. No.	EH040 CC LC	1470001	ESQUEMA No. N-3715 B		
MODELO	EH030 CC LC	1460001	DO NOT REPRODUCE WITHOUT PERMISSION IN WRITING NO REPRODUCIR SIN AUTORIZACION ESCRITA		
No. SERIE	<b>CONTINENTAL</b> CORPORATION, INC.				