

Architectural/Mechanical Product Specifications



GIRBAU, INC.

2500 State Road 44 • Oshkosh, WI 54904
920.231.8222 • FAX 920.231.4666

www.continentalgirbau.com

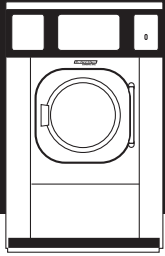

EH030

**E-SERIES 30-POUND CAPACITY
HIGH PERFORMANCE WASHER-EXTRACTOR
FOR ON-PREMISE LAUNDRIES**

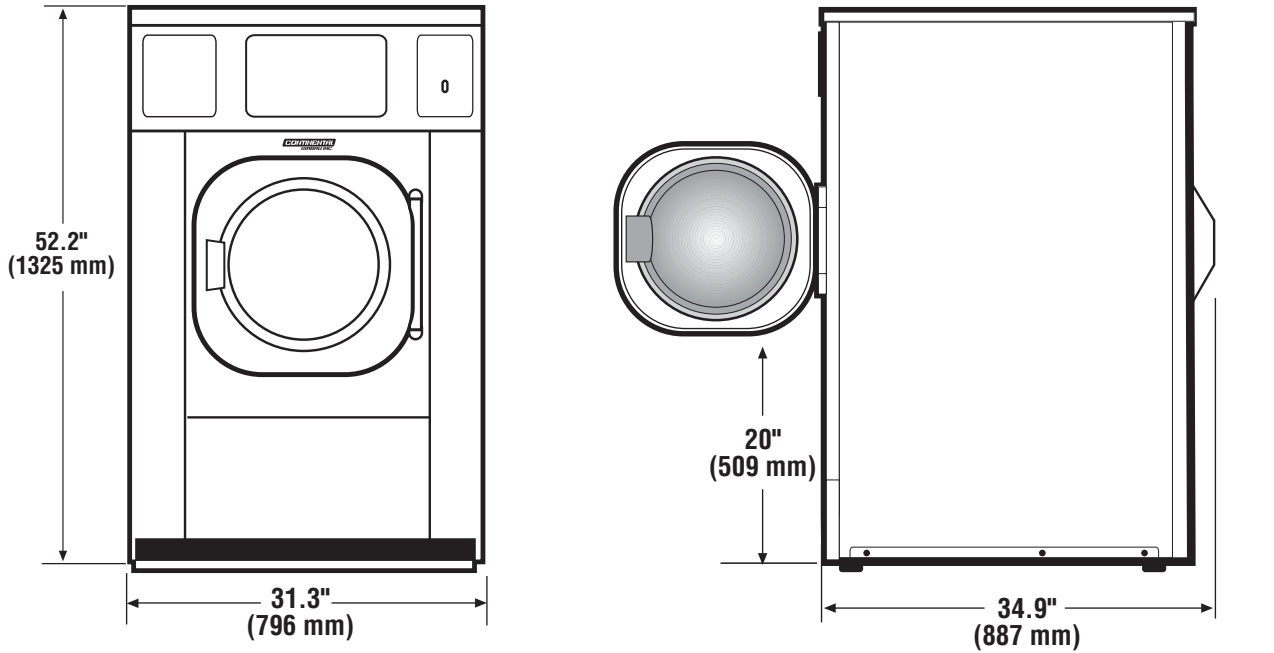

Electrical Data		
Voltage	Wire Config	Amp Protection
208-240/60/1	2W+G	6

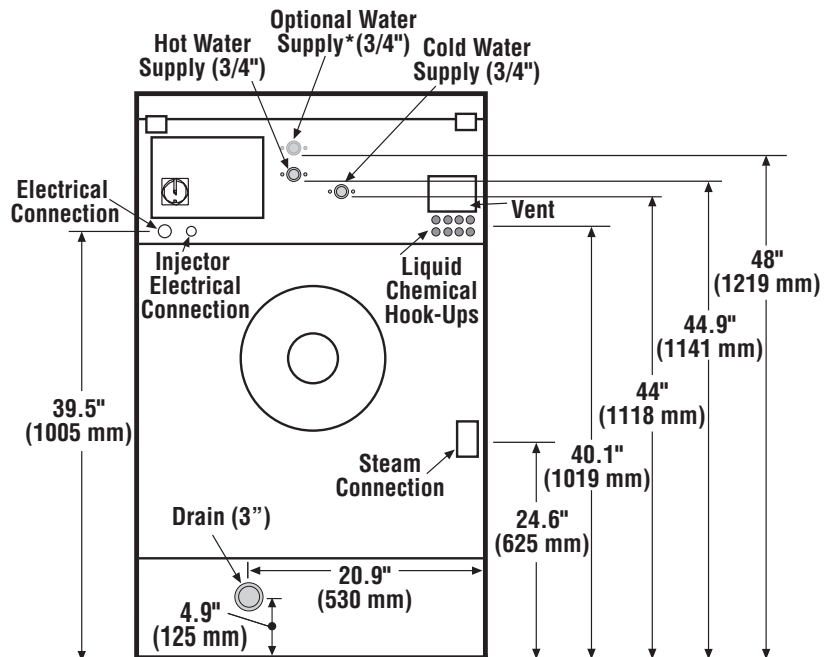

* Optional Water Supply only available on Intelli Control models.

** Specifications subject to change without notice or obligation. Call Continental Girbau, Inc for dimensions not shown or for clarification.



On-Premise Laundry EH030 Product Technical Specifications

Capacity	30 lbs.	(13 kg.)
Cylinder Diameter	24.4 in.	(620 mm.)
Cylinder Depth	16.4 in.	(416 mm.)
Cylinder Volume	4.4 cu. ft.	(126 dm ³)
Net Weight	758 lbs.	(344 kg.)
Crated Weight	820 lbs.	(372 kg.)
Width	31.3 in.	(796 mm.)
Overall Depth	34.9 in.	(887 mm.)
Height	52.2 in.	(1325 mm.)
Door Opening	12.9 in.	(327 mm.)
Floor to Door	20 in.	(509 mm.)
Washing Speed (maximum) Logi Control	46.5 rpm	
Inteli Control	27/36/43/48 rpm	
Spin Speeds	46.5/100/400/600/800/1005 rpm	
G-Force	0.75/3/56/125/222/351	
Static Force Transmitted	902 lbs.	(409 kg.)
Dynamic Force Transmitted	201 lbs.	(91 kg.)
Frequency of the Dynamic Force	16.7 Hz	
Drain Diameter	3 in.	(76 mm.)
Water Inlets (2)	3/4 in.	(19 mm.)
Recommended Water Pressure	30-60 PSI	(2-4 bar)
Water Flow	16 gal/min.	(60 l/min.)
Steam Connection	1/2 in.	(12.7 mm.)
Steam Pressure	29-87 PSI	(2-6 bar)
Steam Flow	176 lbs/h	(80 kg/h)
Motor Power	0.87 kW	
Electric Heating Power (optional)	contact manufacturer for specifications	
Shipping Dimensions (W x D x H)	32.4 x 37.2 x 58.5 in.	(823 x 945 x 1485 mm.)
Modified Energy Factor (MEF)*	2.08	
Water Consumption Factor (WCF)*	4.68	

* Modified Energy Factor (MEF) measured in cubic feet per kilowatt-hour per cycle. Water Consumption Factor (WCF) measured in gallons per cycle per cubic feet. MEF and WCF statistics are according to DOE test results report by Intertek, an independent testing laboratory, dated February 27, 2007.

** Specifications subject to change without notice or obligation. Call Continental Girbau, Inc for dimensions not shown or for clarification.

