

Mechanical Technical Assistance Manual for washers

**MS-613 / EM030, MS-617 / EM040, MS-623 / EM055,
HS-6013 / EH030, HS-6017 / EH040**

GIRBAU, S.A.

Crta de Manlleu, km. 1
08500 VIC (Barcelona) • SPAIN
Tel. 34 93 8861100
Fax 34 93 8860785
girbau@girbau.es
www.girbau.com

For USA & CANADA:

CONTINENTAL GIRBAU Inc.

2500 State Road 44
WI 54904 Oshkosh • USA
Tel. 1(920) 231-8222
Fax 1(920) 231-4666
info@continentalgirbau.com
www.continentalgirbau.com

SERVICE

**MS-613 / EM030, MS-617 /
EM040, MS-623 / EM055,
HS-6013 / EH030, HS-6017 /
EH040**

SAFETY INSTRUCTIONS



WARNING ;

INSPECTION ROUTINES, MAINTENANCE OR REPAIR

- The actions described in these instructions are strictly reserved for Service Technicians who have been authorized by the manufacturer. Any actions carried out by personnel who are unauthorized by the manufacturer will be considered to be improper and will result in the automatic void of washer's warranty.
- The manufacturer will not accept responsibility for any physical and/or material damage caused by actions taken by unauthorized personnel.
- Compliance with the safety warnings listed in the Installation Manual is obligatory; check them before. Read them before servicing the washer.
- Avoid carrying out any course of action on the machine without having first carefully read the washer's installation and operating manuals, paying special attention to the safety instructions.
- Making inspections, maintenance or repairs without taking safety measures or having the necessary technical competence can cause **ELECTRICAL SHOCK OR SERIOUS ACCIDENTS**.
- **COMPLETELY** disconnect the machine from the original power source and check for accidental reconnection.
- Disconnect the electrical connection from the external dosing to the washer. These circuits are independent of the supply to the washer.
- Moving the **ON switch** to the OFF position is not sufficient
- Wait a minimum of (5) five minutes after disconnection to ensure the elimination of residual voltage within the machine.
- Close and mechanically interlock the water supply valves and check that machine has **COMPLETELY** drained, parts have cooled down and that no pieces are in movement through inertia

INDEX

SAFETY INSTRUCTIONS

1. Preparation
 - 1.1. Required tools.
 - 1.2. Parts and materials.
 - 1.3. Parts.
2. Disassembly
 - 2.1. Disassembling the covers
 - 2.2. Dismantling the bearing box.
3. Bearing box
 - 3.1. Disassembling the bearings
 - 3.2. Changing the bearings
 - 3.3. Changing the seal ring.
4. Assembling
 - 4.1 Assembling the bearings' box
 - 4.2 Assembling the covers
6. Final checking
 - 6.1. Checking the machine.

1. PREPARATION

1.1. Required tools.

| DISASSEMBLY ASSEMBLY | TOOLS |
|-------------------------|---|
| Rear cover | TORX 25 screwdriver |
| Top cover | Key supplied with the machine. |
| Drum pulley | 19mm (3/4 inch) wrench. For MS-613 / 617 HS-6013 units 22mm (7/8 inch) wrench. For MS-623 / HS-6017 units. |
| Bearings' box | 13mm tube wrench. 13mm (1/2 inch.) flat wrench Two wrench 17mm (11/16 inch.). |
| Bearings | Nylon-headed hammer (approx. recommended weight: 4kg) |
| Seals ring | 19mm (3/4 inch) wrench. For MS-613 / 617 HS-6013 units 22mm (7/8 inch) wrench. For MS-623 / HS-6017. |

| TOOLS DESCRIPTION | TOOLS | MS-613 / 617 EM030 / 040 HS-6013 / EH030 | MS-623 / EM055 HS-6017 / EH040 |
|---------------------------------|----------|--|-----------------------------------|
| | | CODE | CODE |
| Drum centring device | A | 439711 | 439703 |
| Three legged extractor 1310 LT. | B | 439729 | 439729 |
| Hydraulic Press 15T. | C | | |
| 22mm square-head wrench | D | | |
| Shaft box extension | E | 439695 | 439687 |
| Drum fixing support | M | | |
| Drum fixing cable | P | | |
| Shaft protector | G | 439885 | 439877 |
| Rear bearing inserter | H | 437558 | 437459 |
| Front bearing inserter | I | 437566 | 437467 |
| Extractor for seal ring | J | 437616 | 437525 |
| Inserter for radial seal | K | 438432 | 437509 |
| Inserter for seal ring | L | 439745 | 439737 |
| Drum inserter | N | 439679 | 439661 |
| 46mm. wrench | W | | |

To identify the letters in the TOOLS section, refer to the positions as shown in the various photos throughout the manual.

1.2. Pieces and materials

For identifying the pieces, consult their position in the figures in section 1.3.

| DESCRIPTION | POSITION | QUANTITY |
|--|----------|---|
| Toric gasket $\varnothing 68 \times \varnothing 76 \times 4$ | 12 | 2 |
| Seal ring | 2 | 1 |
| Vring 85. | 3 | 1 |
| Vring plate. | 14 | 1 |
| Seal housing cover | 22 | 1 |
| Toric gasket 6x12x3. | 13 | 6 |
| Seal $\varnothing 85 \times \varnothing 110 \times 12$ BA. | 19 | 1 |
| Bearing 6313 | 21 | 1 |
| Bearing 6310 | 20 | 1 |
| SHELL alvania 3 grease | | 50 gr. (approx) |
| Silicone | | Any kind of non-acid sealing silicon can be used. It is important to use a fine opening applicator. |

1.3. Parts list

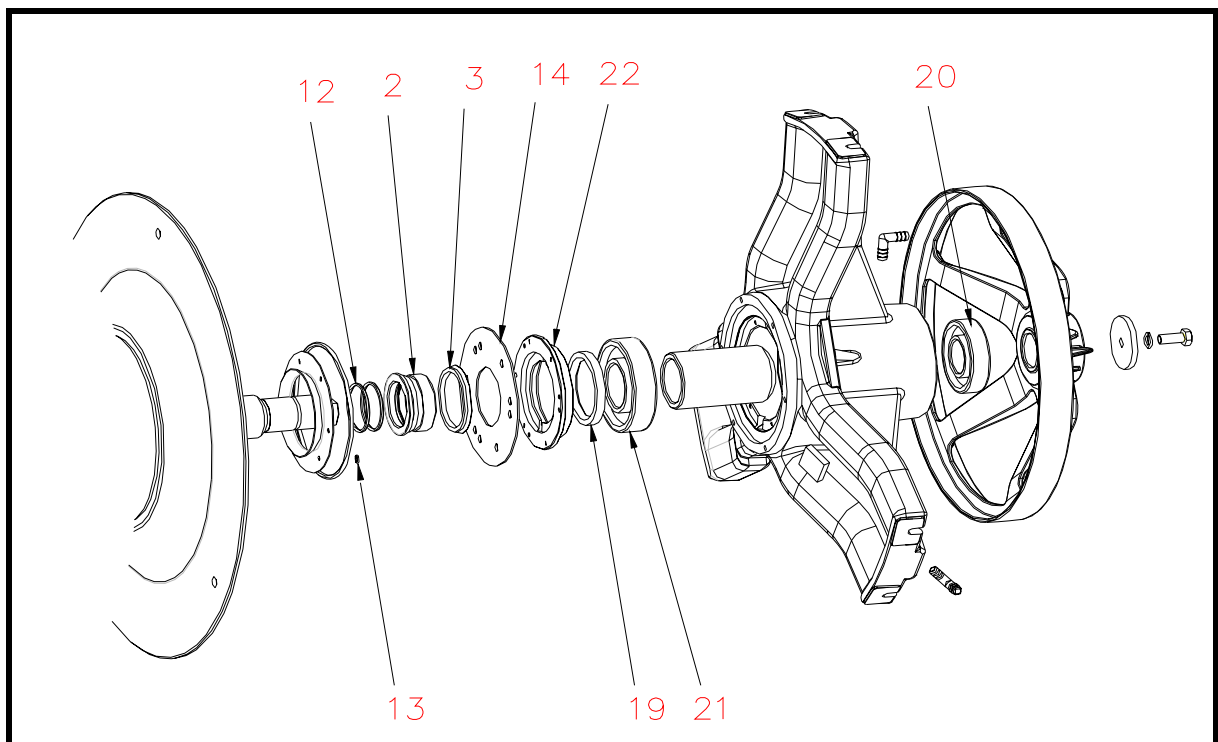

NOTE

The numbers on the drawing above correspond to those from machines parts list HS-6017 / EH040, MS-613 / EM030, MS-617 / EM040 & MS-623 / EM055.

The system for bearing replacement is the same regardless of any differences there may be between the different machine models HS / EH & MS / EM.

2. DISASSEMBLY

2.1. Disassembling the covers.

- Rear central cover. Take out the fastening screws, move the cover upwards and separate it from the machine (*fig. 1*).
- Top cover. Open the top cover using the tools supplied by the manufacturer and remove.



fig.1

2.2. Dismantling the bearing box.

- Open the machine door and fit centring device **A** to the drum aperture. (*fig. 2*).



fig.2

- Remove the overflow connecting hose.
- Open the rear door to the power supply box.
- Dismantle the power supply box **CA** and put to one side to have more room to manoeuvre (only in MS-613, MS-617 and HS-6013 machines). (*fig. 3*).
- Dismantle and slightly move away the dispenser **CD** to have more room to manoeuvre. Remove the hose from the collector.

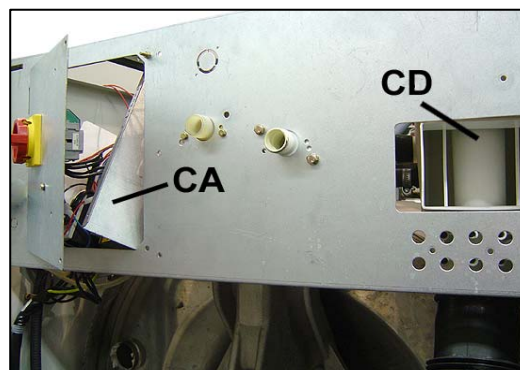

fig. 3

- Remove the belt from the drum pulley.
- Remove the screw fastening the drum pulley. Remove the pulley from the shaft.
- Note down the position of the level sensor tube in order to put it back during assembly.
- Note down the position of the screws and washers in order to put them back during assembly.
- Take out the **X** nuts (*fig.*) fastening the bearings' box to the back of the outer drum.
- Take out the **Y** screws (*fig. 4*) fastening the bearings' box to the outer drum.

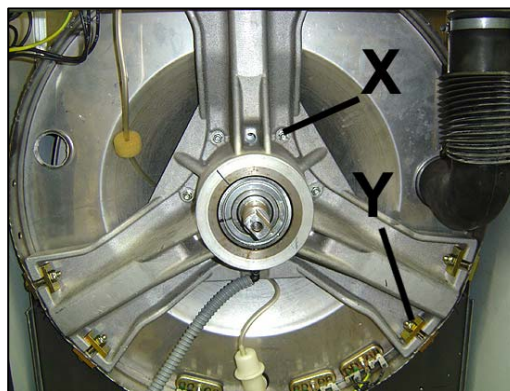

fig. 4

(It is advisable to have this operation performed by two people)

- ⚠ Remember to lubricate the tool bolts to avoid any jamming.
- Check that press bolt **C** is completely unscrewed.
- Place the protective cover on the shaft, fit the hydraulic press **C**, fit extractor **B** and tighten all slightly using the 22mm square-head wrench **D**.
- Screw together the hydraulic press **C** and the extractor **B** until the box is released from the shaft. (fig. 5).

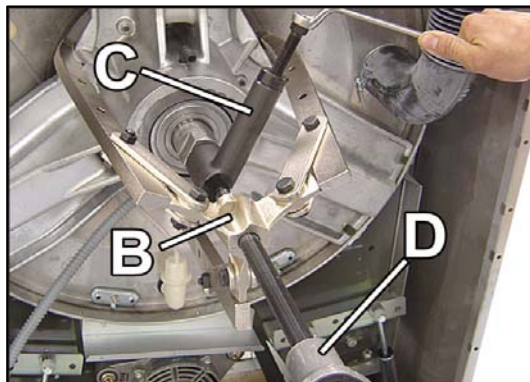

fig. 5

⚠ IMPORTANT

This operation must be carried out with extreme care to avoid the risk of knocking either of the two bearings.

- Once the box is released remove the tools, fit shaft extension **E** and remove the bearings box. (fig. 6).



fig. 6

3. BEARINGS' BOX

3.1. Disassembling the bearings.

- Place the bearing box in such a way that the Vring protection plate can be removed.
- Remove the Vring protection plate using the fixed wrench. (fig. 7).



fig. 7

- ⚠ Remember to lubricate the tool bolt to avoid any jamming.
- Turn the box round so that bearings can move.
- Place the rear bearing extractor **I** on the bearing box and protect the extractor screw with tool **G**.
- Remove the set using extractor **B** and the 22mm square-head wrench. (fig.8).

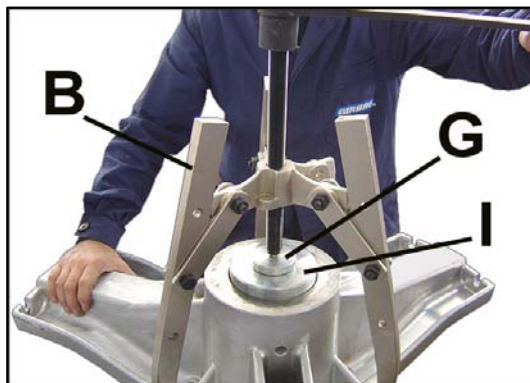

fig.8

3.2. Changing the bearings.

- Clean the bearings' box, especially the area housing the bearings, lightly lubricate the bearing housing to make it easier to mount.
- Lean the conical trunk end of the bearings' box on a hard, clean and flat surface.
- Position the front bearing in its housing (the numbered side of the bearing in the external part). Introduce it up to the end of the box using the **H** tool (*fig. 9*).



fig. 9

- Place the radial seal on the seal housing cover with the spring facing upwards and using **K** tool make sure it is inserted as far as it will go. (*fig. 10*).



fig. 10

- Spread a little grease on the inside of the radial lip seal, just where the spring is.
- Apply a fine thread of silicon on the seal housing cover, skirting round the drilled holes for drainage and air vent. (*fig. 11*).

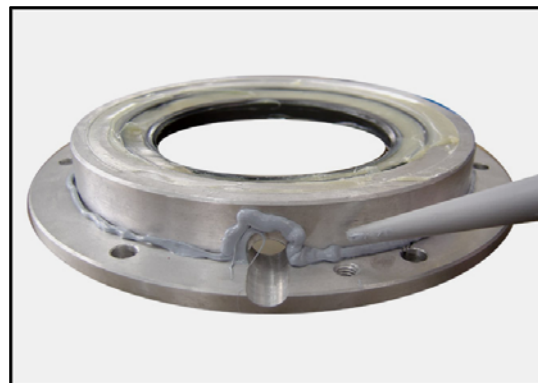

fig. 11

- Place the seal housing cover on the inside of the box, bearing in mind the position of the drainage hole and the air vent
- Apply a fine thread of silicon to the cover as shown in the photograph. (*fig. 12*).

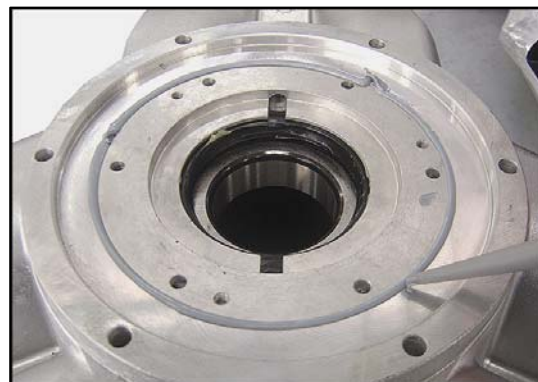

fig. 12

MS-613 / EM030, MS-617 / EM040, MS-623 / EM055
HS-6013 / EH030, HS-6017 / EH040

- Put the Vring plate in position and place the toric gaskets in the drill holes. (fig. 13).

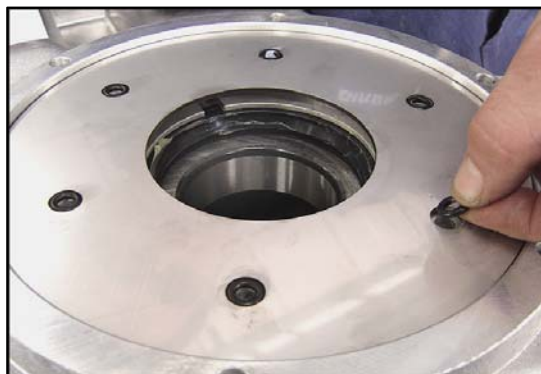

fig. 13

- Place the Vring protection plate in position and finish assembling the bearing box using the 6x25 bolts. (fig. 14).



fig. 14

- Using a fine object, clean off any excess silicone from the drainage and air vent holes. (fig. 15).



fig. 15

- Turn the box and insert the cover for the bearings into the box with the conical end facing outwards. (fig. 16).



fig. 16

- Position the rear bearing in its housing (the numbered side of the bearing in the external part). Introduce it up to the end of the separator using I tool (*fig. 17*).
- Check that the bearings' end piece is pressed between the two bearings.



fig. 17

3.3. Changing the seal ring

- This procedure is carried out from behind through the space left by the central hole in the outer drum.
- Remove the Vring seal and remove the ring seals from the drum shaft using tool J. (*fig. 18*).
- Remove the toric gaskets from inside the ring.

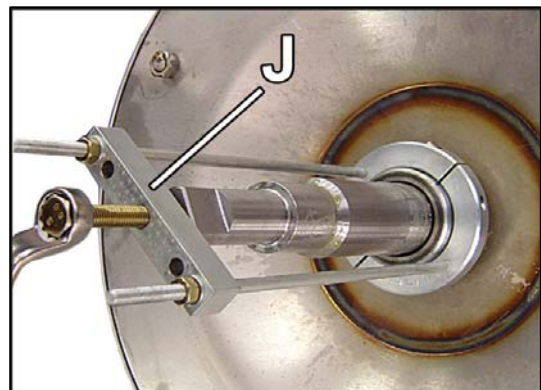

fig. 18

- Insert the two new toric gaskets inside the seal ring (*fig.19*).



fig. 19

- This procedure is carried out from behind through the space left by the central hole in the outer drum.
- Lubricate the shaft with soapy water to make the assembly easier, insert the seal ring into the shaft using tool L until it meets flush with the drum star. (*fig. 20*).

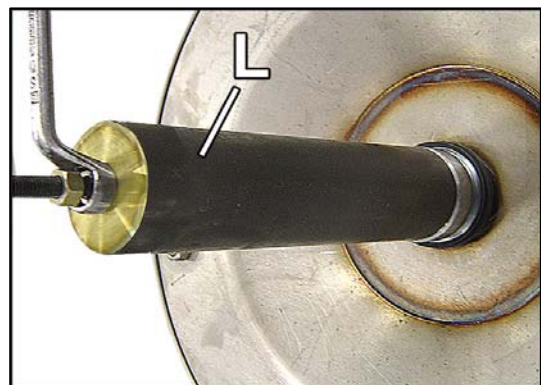

fig. 20

- Insert the Vring with the lip facing upwards on the outside of the ring paying special attention to the position of the lip. (fig. 21).



fig. 21

4 Assembling

4.1. Assembling the bearings' box.

 **IMPORTANT**
This operation must be carried out with extreme care to avoid the risk of knocking either of the two bearings.

(It is advisable to have this operation performed by two people)

- Fix extension **E** on to the shaft.
- Position the bearing box in the drum shaft making sure to match up the fixing points. Remember the drainage hole is on the bottom part. (fig. 22.)



fig. 22

- Mount the fixing support **M**.
- Fix cable **P** on the outer part of the shaft extension **E**.
- Tighten cable **P** until the bearing box is centred with the outer drum. (fig. 23).
- Push the bearings box towards the inside until it fits into the central studs at the bottom of the outer drum.
- Remove the support **M**, tightening cable **P** and extension **E**.

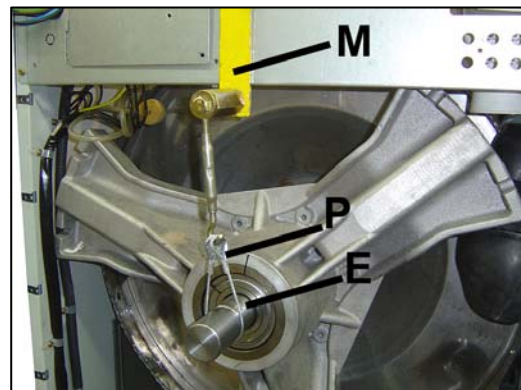

fig. 23

-  Remember to lubricate the tool bolt to avoid any jamming.
- Fix inserter tool **N** keeping the bolt outside firmly locked with a 46mm wrench and tightening the inside nut with the other 46mm wrench **W** until the bearing box is at the bottom. (fig. 24).



fig.24

- Fix the bearing box to the bottom of the outer drum using nuts **X** and the corresponding washers.(fig. 25). Do not tighten.
- Fasten the ends of the bearings' box to the edge of the outer drum by means of the **Y** screws and the corresponding nuts and washers (fig. 25).
- Avoid letting the level sensor tube become pressed by the bearings' box.
- Tighten the central fastening screws **X** first and then the peripheral ones **Y**.

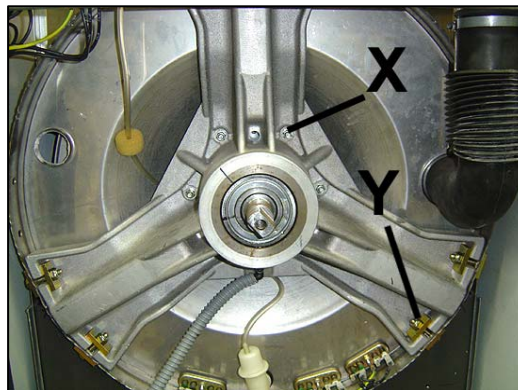

fig. 25

- Replace the power supply box **CA**. (fig. 26).
- Close the rear door to the power supply box.
- Replace the dispenser **CD** and the hose from the collector.
- Replace the overflow pipe.

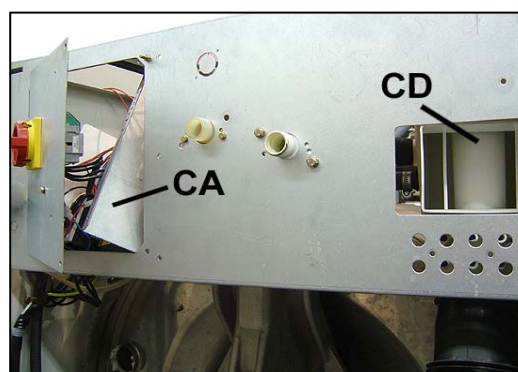

fig. 26

- Remove the centring device **A** from the drum opening.
- Replace the pulley and tighten the fixing screw.
- Check the drum turns freely
- Replace the belt. (fig. 27).



fig. 27

4.2. Assembling the covers.

- Rear central cover. Position the rear cover beneath the rear panel and fix in place with the screws. (fig. 28).
- Top cover. Insert the cover into the two rear hinges and close with the keys supplied by the manufacturer.



fig.28

5. FINAL CHECKING

5.1. Checking the machine.

Once **ALL** the washing machine covers are in place and fastened, check the operation and water tightness of the washing machine.



Procedure:

- Check that the drainpipe outlet is placed and fastened correctly.
- Open the manual water supply valves.
- Connect the power supply of the washing machine.
- Load the washing machine with clothes.
- Select a washing program. It is preferable to use a program with high temperature.
- Run the selected program. During the execution of the washing cycle, check that no alarms appear, which indicate a malfunction in the machine, especially those related with the inverter, motor.
- Once finalized, disconnect the power supply and close the manual valves of the water inlets.
- Take the front lower cover and the rear cover off.
- Check that the base of the machine is dry and that no bath loss occurs, especially in the joints of the front panel of the outer drum and the door gasket.
- Check that no bath loss occurs, especially in the joints of the bearings' box and the back of the outer drum or through the drainage tube.
- In the case of not observing any kind of anomaly, put the covers on.
- Open the manual valves and connect the power supply.

Remember that:

- In LOGI Control machines, there is the possibility of accelerating up the program (see Instruction Manual, section 2.5).
- In COIN machines, there is the possibility of using the DEMO program (see Advanced Instruction Manual, section 3.4).
- In INTELI Control machines, there is the possibility of accelerating up the program (see Instruction Manual, section 4.4).